

RoHS Compliant 

本部品不含有環境管理物質規定之有害物質  
kaler part does not contain harmful substances

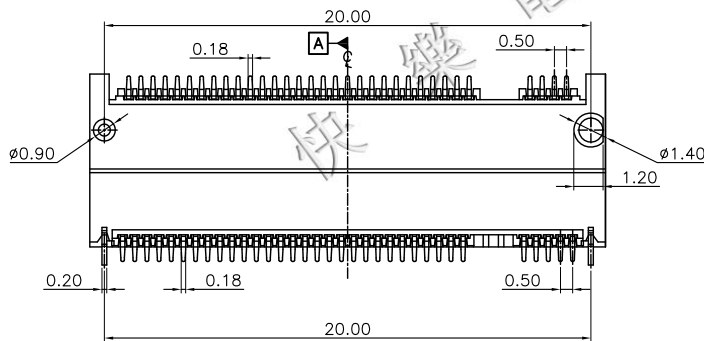

Center Line of Card

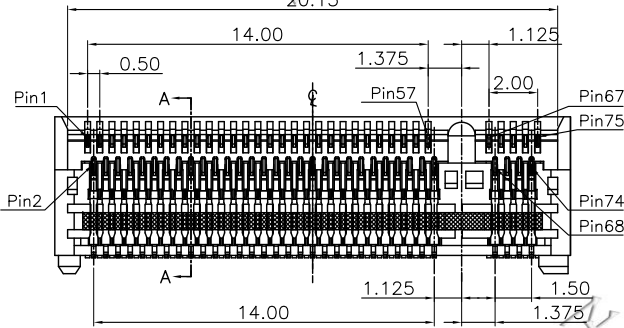
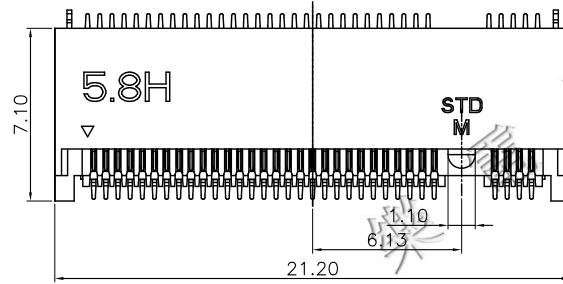
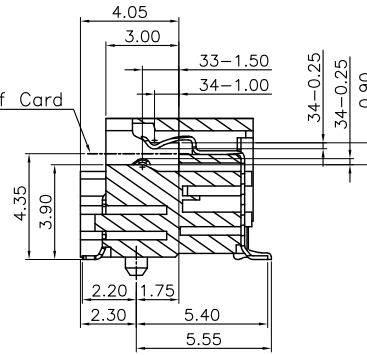

Section A-A

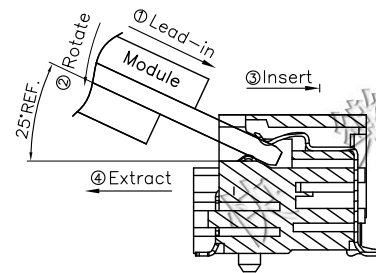
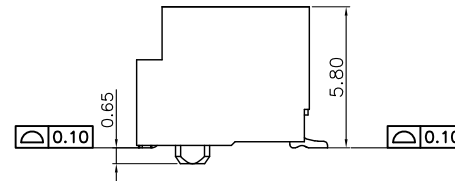

How to mate and unmate  
Mate: ①-②-③  
Unmate: ④

Notes:

1.Kaler Part Material Description

1.1 Housing:High Temperature Thermoplastic, Black UL 94V-0.

1.2 Contact:Copper Alloy,Gold Plating at Mating Area.Matte Tin Plating at Solder Tail, All over Nickel.

1.3 Leg:Copper Alloy,Matte Tin Plating over All, All over Nickel.

3. Ratings

3.1 Voltage Rating: 50V AC (Per pin);

3.2 Current Rating: 0.5A (Per pin);

3.3 Operating Temperature: -25°C ~ 85°C;

4. Electrical Requirement:

4.1 LLCR: 55mΩ Max,(Initial), 20mΩ Max. change allowed(Final);

4.2 Dielectric Withstanding Voltage: 300V AC (RMS) for 1 minute;

4.3 Insulation Resistance: 500MΩ Min. @ 500V DC.

5. Mechanical Requirement:

5.1 Mating Force: 20N Max.

5.2 Unmating Force: 20N Max.

5.3 Durability: 60 Cycles.

NF27-01M0 x

Contact plated:

1:Contact area G/F, Solder tail G/F;

2:Contact area Au 3u", Solder tail G/F;

3:Contact area Au 5u", Solder tail G/F;

4:Contact area Au 10u", Solder tail G/F;

5:Contact area Au 15u", Solder tail G/F;

6:Contact area Au 30u", Solder tail G/F;

SCALE	N/A	DESIGNER	CHEN	22/9/22
REV	A	CHECKED	PANG	22/9/22
SHEET	1	APPROVE	JOHN	22/9/22

UNLESS OTHKRWISE SPECIFIED DIMENSIONS ARE IN mm

DIMRNSION	TOLERANCE
.XX	± 0.20
.X	± 0.30
X .	± 0.50
ANGULAR	± 3°
UNIT	mm



快樂電子有限公司  
KALER KALER ELECTRONICS CO.,LTD.

TITLE:	NGFF Socket (M.2 Connector) 5.8H, STD M Key
PART NO.	NF27-01M01
DWG.NO.	

REVISIONS				
REV.	ECN NO.	LOCATION	DESCRIPTION	DATE
			INITIALRELEASE	



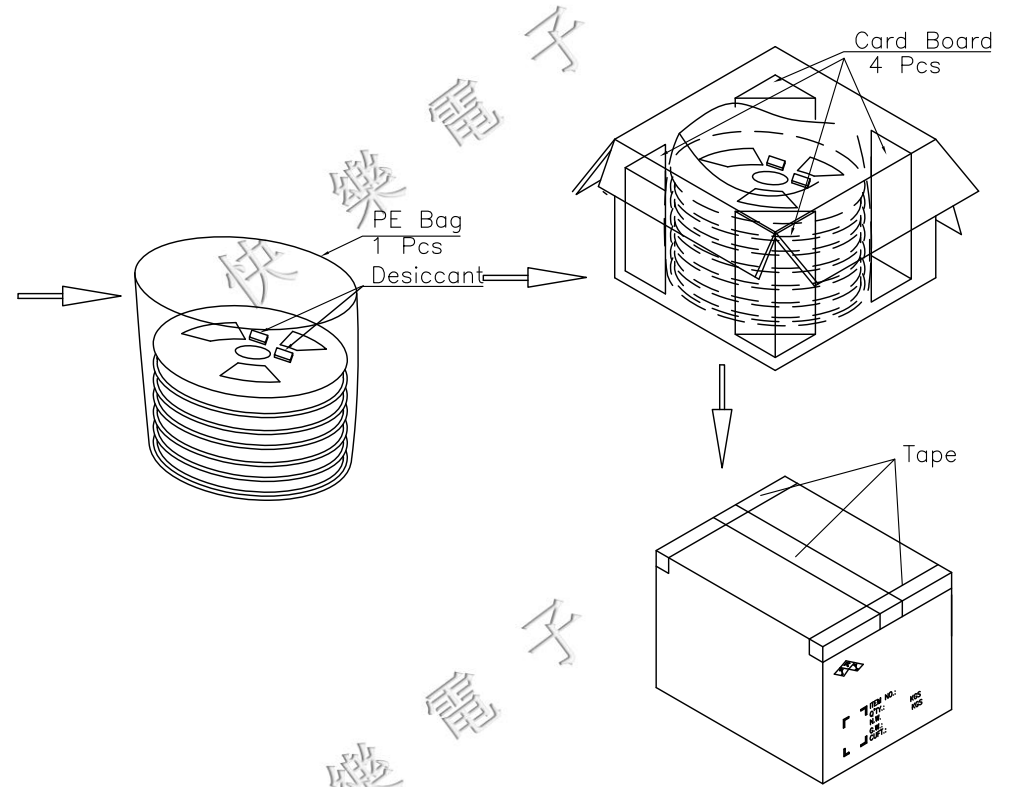
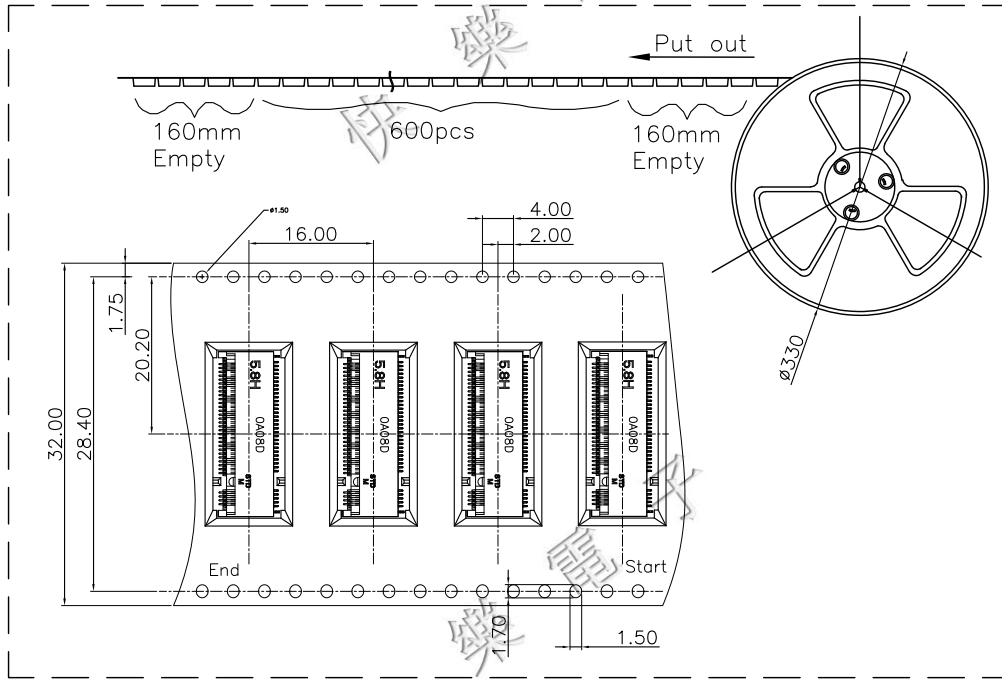

RoHS Compliant 

本部品不含有環境管理物質規定之有害物質  
kaler part does not contain harmful substances



Notes:

1. Peel off force of top tape: 0.1~1.3N;
2. 600 pcs/reel, 6000 pcs/carton.

					SCALE	N/A	DESIGNER	CHEN	22/9/22	UNLESS OTHKRWISE SPECIFIED DIMENSIONS ARE IN MM	 <b>快樂電子有限公司</b> <b>KALER ELECTRONICS CO.,LTD.</b>										
					REV	A	CHECKED	PANG	22/9/22			DIMRNSION TOLERANCE .XX ± 0.20 .X ± 0.30 X . ± 0.50 ANGULAR ± 3° UNIT mm 	TITLE:	NGFF Socket (M.2 Connector) 5.8H, STD M Key							
					SHEET	3	APPROVE	JOHN	22/9/22				PART NO.	NF27-01M01							
					REVISIONS <table border="1"> <thead> <tr> <th>REV.</th> <th>ECN NO.</th> <th>LOCATION</th> <th>DESCRIPTION</th> <th>DATE</th> </tr> </thead> <tbody> <tr> <td></td> <td></td> <td></td> <td>INITIALRELEASE</td> <td></td> </tr> </tbody> </table>					REV.	ECN NO.	LOCATION	DESCRIPTION	DATE				INITIALRELEASE		DWG.NO.	
REV.	ECN NO.	LOCATION	DESCRIPTION	DATE																	
			INITIALRELEASE																		