

RoHS Compliant

本部品不含有環境管理物質規定之有害物質
kaler part does not contain harmful substances

Notes:

1.Kaler Part Material Description

- 1.1 Housing:High Temperature Thermoplastic, Black UL 94V-0.
- 1.2 Contact:Copper Alloy,Gold Plating at Mating Area,Matte Tin Plating at Solder Tail, All over Nickel.
- 1.3 Leg:Copper Alloy,Matte Tin Plating over All, All over Nickel.

3. Ratings

- 3.1 Voltage Rating: 50V AC (Per pin);
- 3.2 Current Rating: 0.5A (Per pin);
- 3.3 Operating Temperature: -25°C ~ 85°C;

4. Electrical Requirement:

- 4.1 LLCR: 55mΩ Max,(Initial), 20mΩ Max. change allowed(Final);
- 4.2 Dielectric Withstanding Voltage: 300V AC (RMS) for 1 minute;
- 4.3 Insulation Resistance: 500MΩ Min. @ 500V DC.

5. Mechanical Requirement:

- 5.1 Mating Force: 20N Max.
- 5.2 Unmating Force: 20N Max.
- 5.3 Durability: 60 Cycles.

NF09-01M0 x

└ Contact plated:

- 1:Contact area G/F, Solder tail G/F;
- 2:Contact area Au 3u", Solder tail G/F;
- 3:Contact area Au 5u", Solder tail G/F;
- 4:Contact area Au 10u", Solder tail G/F;
- 5:Contact area Au 15u", Solder tail G/F;
- 6:Contact area Au 30u", Solder tail G/F;

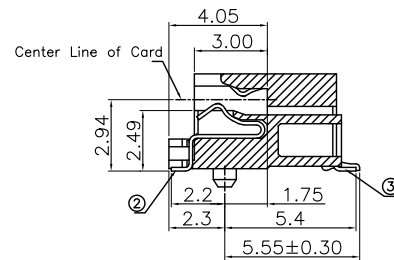
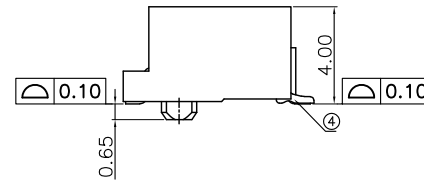
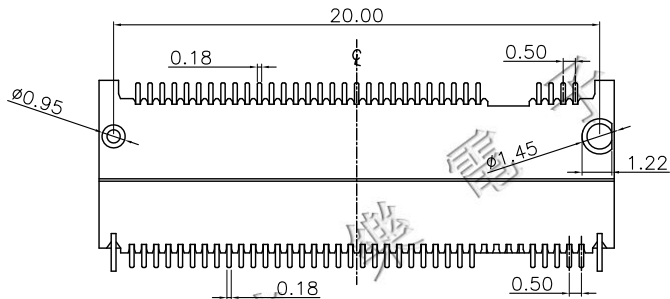
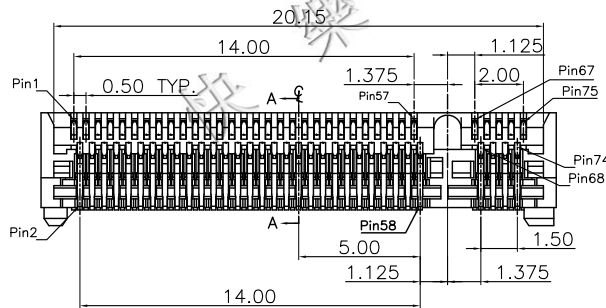
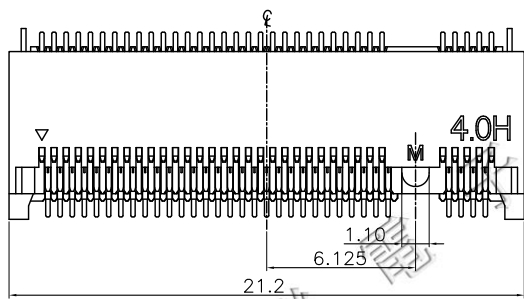

Section: A-A

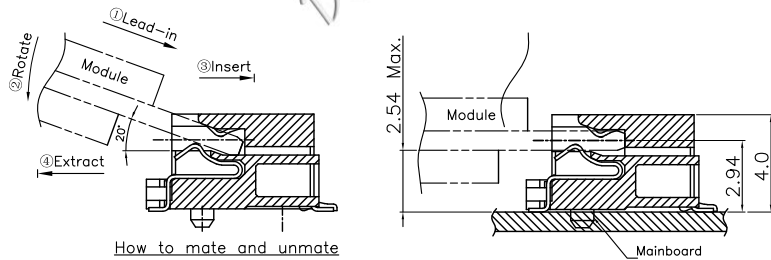

How to mate and unmate
Mate: ①-②-③
Unmate: ④

SCALE	N/A	DESIGNER	CHEN	22.9.22
REV	A	CHECKED	PANG	22.9.22
SHEET	1	APPROVE	JOHN	22.9.22

UNLESS OTHKRWISE SPECIFIED DIMENSIONS ARE IN mm

DIMRNSION	TOLERANCE
.XX	± 0.20
.X	± 0.30
X .	± 0.50
ANGULAR	± 3°
UNIT	mm



快樂電子有限公司
KALER ELECTRONICS CO.,LTD.

TITLE:	NGFF Socket (M.2 Conn.) 4.0H, STD M Key
PART NO.	NF09-01M01
DWG.NO.	

REVISIONS				
REV.	ECN NO.	LOCATION	DESCRIPTION	DATE
			INITIALRELEASE	

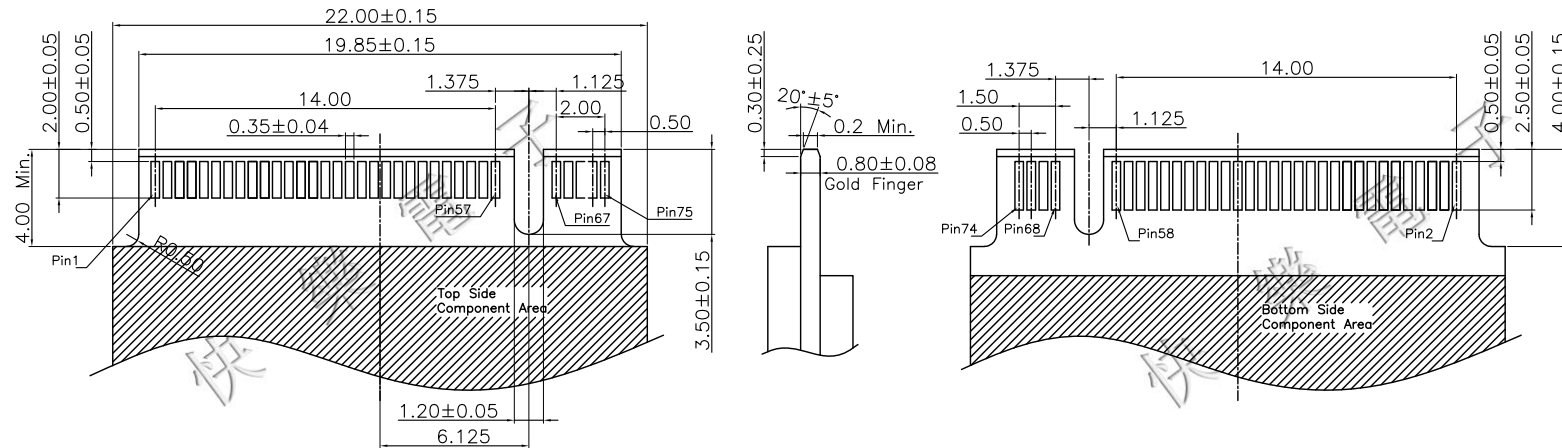

Recommended Mould Finger Layout
Default Tolerance ±0.05

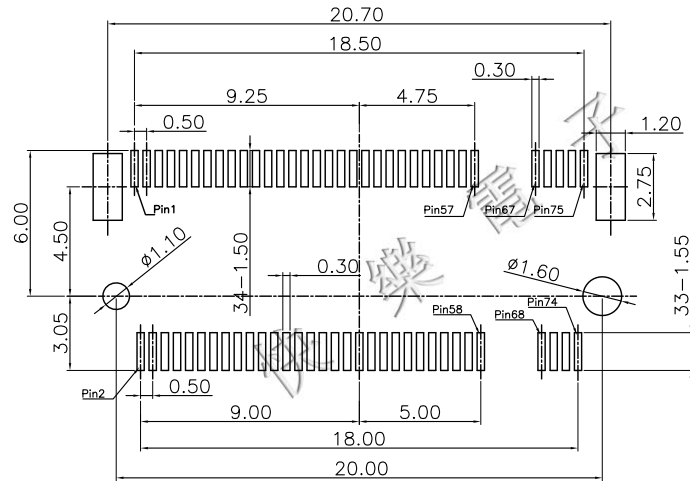

Recommended PCB Layout (Top View)
Default Tolerance ±0.05

SCALE	N/A	DESIGNER	CHEN	22.9.22
REV	A	CHECKED	PANG	22.9.22
SHEET	2	APPROVE	JOHN	22.9.22

UNLESS OTHERWISE SPECIFIED DIMENSIONS ARE IN mm	
DIMRNSION	TOLERANCE
.XX	± 0.20
.X	± 0.30
X .	± 0.50
ANGULAR	± 3°
UNIT	mm 



快樂電子有限公司
KALER ELECTRONICS CO.,LTD.

REVISIONS				
REV.	ECN NO.	LOCATION	DESCRIPTION	DATE
			INITIALRELEASE	

TITLE:	NGFF Socket (M.2 Conn.) 4.0H, STD M Key
PART NO.	NF09-01M01
DWG.NO.	

RoHS Compliant 

本部品不含有環境管理物質規定之有害物質
kaler part does not contain harmful substances

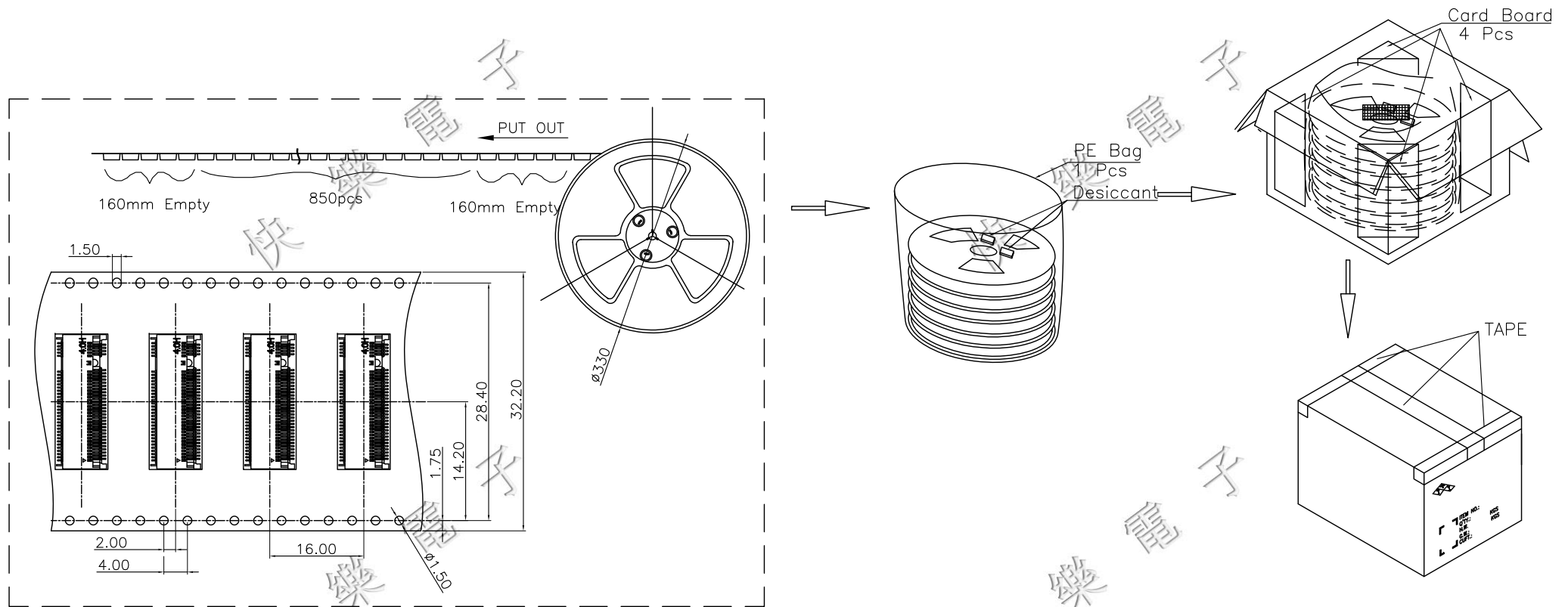

Notes:

1. Peel off force of top tape: 0.1~1.3N;
2. 850 pcs/reel, 8500 pcs/carton.

SCALE	N/A	DESIGNER	CHEN	22.9.22
REV	A	CHECKED	PANG	22.9.22
SHEET	3	APPROVE	JOHN	22.9.22

UNLESS OTHKRWISE SPECIFIED DIMENSIONS ARE IN mm

DIMRNSION	TOLERANCE
.XX	± 0.20
.X	± 0.30
X .	± 0.50
ANGULAR	± 3°
UNIT	mm 



快樂電子有限公司
KALER ELECTRONICS CO.,LTD.

REVISIONS				
REV.	ECN NO.	LOCATION	DESCRIPTION	DATE
			INITIALRELEASE	

TITLE:	NGFF Socket (M.2 Conn.) 4.0H, STD M Key
PART NO.	NF09-01M01
DWG.NO.	